

HILLARYS YACHT CLUB

Sailing Handbook

2009 – 2010

Cruising Division
Dinghy Racing Division
Keelboat Racing Division

- CALENDAR
- CONTACTS
- INSTRUCTIONS
- COURSES

WELCOME

Introduction

Welcome sailors old and new to the new sailing season. With growing fleets and new events what a season it promises to be.

While HYC maintains a strong presence in the senior off-shore racing fleet it's at the other end of the sailing spectrum where some of our most pleasing growth is happening. The shift of dinghy sailing from Sunday to Saturday racing was an inspired decision last season and this, together with the concentrated effort by club coaches and trainers has seen a very rewarding growth in our dinghy numbers. We expect to maintain this growth in the forthcoming season and to continue to see our youth representing us on the water at regattas throughout the state. Good luck to them.

The Cruising in Company will once again cater for yachties with a sense of fun and adventure – without the pressure of organizing crew, and repairing gear, for weekly competitive racing. There is once again a full program of organized cruises interspersed with the usual twilight sailing season which commences off the spectacularly new HYC club premises early in the New Year.

The Keelboats are experiencing growth in the fleet sizes as they participate in a varied season of racing. The Carpet Choice North Coast Series will once again be a highlight. This event attracts a large combined fleet from HYC and Ocean Reef Sea Sports Club in the neutral waters off Mullaloo beach. This inter-club series has really taken off and the windward - leeward format of close racing has noticeably lifted the sailing skills of both clubs. HYC are the current trophy holders, but we can expect a strong challenge from the ORSSC fleet in 2009-10.

This season sees the introduction of something altogether new to HYC - a Short-Handed series. Conducted each fortnight from January to April it aims to cater for the sailor looking for an organized excuse to sail during the week. Single-handed sailors are especially encouraged to give this series a try!

I hope this book meets the aim of providing a ready reference to the programs of our HYC based sailing sections. There is a lot happening in 2009-2010, all of which will see HYC go from strength to strength as one of the premier sailing clubs in WA. Let's all be in it!!

Chris Grant
Rear Commodore Sailing

Index

Introduction.....	1
Index.....	2
<u>COMBINED HYC CALENDAR OF EVENTS 2009 - 2010</u>	4
1.0 Sailing Section Contacts.....	11
<u>CRUSING DIVISION</u>	
2.0 Cruising in Company Information	11
<u>DINGHY RACING DIVISION</u>	12
4.0 Hillarys Yacht Club Dinghy Racing Instructions	13
4.1 Rules.....	13
4.2 Eligibility.....	13
4.3 Notices to Competitors.....	13
4.4 Changes to Sailing Instructions.....	13
4.5 Signals Made	
Ashore.....	13
4.6 Schedule of Events.....	14
4.7 Class Flag.....	14
4.8 The Course.....	14
4.9 Marks	14
4.10 The Start.....	15
4.11 Change of Course after the start.....	15
4.12 The Finish.....	15
4.13 Penalty System.....	15
4.14 Time Limits.....	16
4.15 Protests and Requests for Redress.....	16
4.16 Meditation.....	16
4.17 Scoring.....	17
4.18 Safety Regulations.....	17
4.19 Official Boats.....	18
4.20 Radio Communication	18
4.21 Disclaimer of Liability.....	18
4.22 Insurance.....	18
4.23 Prizes.....	18
4.24 Rules for Determination.....	19
<u>COURSES</u>	20 - 23
<u>KEELBOAT RACING DIVISION</u>	24
6.0 H YC Keelboat Racing Instructions	24
6.2 Eligibility to Compete.....	24
6.3 Safety Requirements.....	25
6.4 Sailing Instructions.....	26
6.5 Schedule of Races.....	26
6.6 Class Flags.....	26
6.7 Racing Area	26

6.8	Commercial Shipping.....	27
6.9	Courses.....	27
6.10	Marks	27
6.11	Responsibility and Liability	27
6.12	Radio Communications	27
6.13	Starting Line	28
6.14	Starting Procedures.....	28
6.15	Finishing Line.....	29
6.16	Shorten Course	30
6.17	Time Limits and Finishing Times	30
6.18	Missing Marks	30
6.19	Results	30
6.20	Protests.....	31
6.21	Meditation.....	31
6.22	Distinguishing Flags - Rescue Boats.....	32
6.23	Handicaps	32
6.24	Consistency Points.....	32
6.25	Advertising.....	32
6.26	Twilight Sailing.....	33
Appendix A1	Sailing Courses – Inshore	34
Appendix A2	Keelboat Midi-Series Courses that will be used instead of the mini series course if a start boat is not available.....	38
Appendix A3	North Coast Series	40
Appendix A4	Offshore Sailing Courses.....	41
Appendix B	Race Marks.....	45
Appendix C	Table of Bearings and Distances between marks.. ..	46
Appendix D	Handicap & Scoring System.....	48
HYC Race Area	49

COMBINED PROGRAMME 2009 - 2010

DATE	DAY	SECTION	TIME	EVENT
19/09/09	Fri	Offshore Division	0925	YWA/SoPYC Around The Sound OffshoreE
20/09/09	Sun	CiC	TBC	CiC Dinghy Cruise Moore River
03/10/09	Sat	Offshore Division	0930	YWA/FSC LAW FOUNDATION RACE
04/10/09	Sun	All Sections	1400	Opening of Season Day/Commodore's Cup
04/10/09	Sun	All Sections	1410	Opening Day/Commodore's Cup JAM
07/10/09	Wed	Dinghy Division	1700	Dinghy Training
08/10/09	Thu	CiC	1930	CiC Meeting – 1830 Dinner – HYC
10/10/09	Sat	Dinghy Division	1000	Dinghy Racing
11/10/09	Sun	Keelboat Division	1330	Consistency Series 1 Race 1
14/10/09	Wed	Dinghy Division	1700	Dinghy Training
15/10/09	Thu	Keelboat Division	1930	Monthly Meeting
17/10/09	Sat	Dinghy Division	0945	Dinghy Racing
18/10/09	Sun	Offshore Division	1000	Offshore Race 1 Marmion Reef Race
21/10/09	Wed	Dinghy Division	1700	Dinghy Racing
23/10/09	Fri	Offshore Division	1325	YWA/SoPYC GERALDTON OCEAN CLASSIC
24- 25/10/09	Sat/ Sun	CiC	0830	CiC Fremantle Sailing Club Cruise and Roundhouse Tour
24- 25/10/09	Sat/ Sun	Dinghy Division	0900	FSC Indian Ocean Regatta - Dinghy
25/10/09	Sun	Keelboat Division	1330	Consistency Series 1 Race 2 - Handicap
25/10/09	Sun	Keelboat Division	1335	JAM Series 1
28/10/09	Wed	Dinghy Division	1700	Dinghy Training and Meeting 1900hrs
30/10/09	Fri	Offshore Division	0925	YWA/FSC GERALDTON RETURN RACE
31/10/09	Sat	Dinghy Division	0945	Dinghy Section
01/11/09	Sun	Keelboat Division	1330	Consistency Series 1 Race 3
04/11/09	Wed	Dinghy Division	1700	Dinghy Training
07/11/09	Sat	Dinghy Division	0945	Dinghy Training
7- 8/11/09	Sat/ Sun	CiC	0830	CiC Stark Bay Cruise and Shelf Champagne Sail
08/11/09	Sun	All Sections	0830	National Go Sailing Day (no racing)
11/11/09	Wed	Dinghy Division	1700	Dinghy Training
12/11/09	Thu	CiC	1930	CiC Meeting – 1830 Dinner – HYC
14/11/09	Sat	Dinghy Division	0945	Dinghy Training
14/11/09	Sat	Offshore Division	0925	YWA/FSC COVENTRY REEF RACE
14/11/09	Sat	Keelboat Division	1000	North Coast Series Race 1 Mullaloo Beach
15/11/09	Sun	Offshore Division		HARBOUR RACE
18/11/09	Wed	Dinghy Division	1700	Dinghy Training

19/11/09	Thu	Keelboat Division	1930	Monthly Meeting
21- 22/11/09	Sat/ Sun	CiC	0700	CiC Interclub and Owen Anchorage - tentative
21- 22/11/09	Sat/ Sun	Dinghy Division	1000	RPYC Mini Series - Dinghy
21/11/09	Sat	Offshore Division	1040	YWA/RFBYC ROLAND SMITH
22/11/09	Sun	Offshore Division	1055	YWA/RFBYC GORDON CRAIG
22/11/09	Sun	Keelboat Division	1330	Consistency Series 1 Race 4
25/11/09	Wed	Dinghy Division	1700	Dinghy Training and Meeting 1900hrs
28/11/09	Sat	Dinghy Division	0945	Dinghy Racing
28/11/09	Sat	Keelboat Division	1000	Offshore Race 2 HYC - Fremantle
29/11/09	Sun	Keelboat Division	1000	Offshore Race 3 Fremantle - HYC
02/12/09	Wed	Dinghy Division	1700	Dinghy Training
05/12/09	Sat	Offshore Division	0925	YWA/RFBYC BUNBURY & RETURN RACE
05/12/09	Sat	Dinghy Division	0945	Dinghy Racing
06/12/09	Sun	Keelboat Division	1330	Consistency Series 1 Race 5
06/12/09	Sun	Keelboat Division	1335	JAM Series 2
09/12/09	Wed	Dinghy Division	1900	Dinghy Training
10/12/09	Thu	CiC	1930	CiC Meeting – 1830 Dinner – HYC
12- 13/11/09	Sat/ Sun	Dinghy Division		RFBYC ICR - Dinghy
12/12/09	Sat	CiC	1800	Christmas Party at Steve & Miriam's
13/12/09	Sun	Keelboat Division	1000	North Coast Series Race 2 – Mullaloo Beach
16/12/09	Wed	Dinghy Division	1700	Dinghy Training
17/12/09	Thu	Keelboat Division	1930	Monthly Meeting
19/12/09	Sat	Dinghy Division	0945	Christmas Fun Day - Dinghy
27/12/09	Sat	Dinghy Division		Laser Nationals/Optimist Nationals Adelaide Aus Youth Champs - Dinghy
				XMAS - NEW YEARS BREAK
10/01/10	Sun	Keelboat Division	1330	Consistency Series 2 Race 1
13/01/10	Wed	Dinghy Division	1700	Dinghy Training
14/01/10	Thu	Keelboat Division	1000	Short-handed Series Event 1
14/01/10	Thu	CiC	1930	CiC Meeting – 1830 Dinner – HYC
15/01/10	Fri	All Division	1800	Twilight Event 1
16- 17/01/10	Sat/ Sun	CiC	0830	CiC Fremantle Sailing Club Cruise – and Ovens Submarine Tour
16/01/10	Sat	Offshore Division	0925	CAPE VLAMINGH
16/01/10	Sat	Dinghy Division	0945	Dinghy Racing

17/01/10	Sun	Keelboat Division	1330	Consistency Series 2 Race 2 (Handicap)
20/01/10	Wed	Dinghy Division	1700	Dinghy Training
20/01/10	Wed	Keelboat Division	1930	Monthly Meeting
22/01/10	Fri	All Divisions	1800	Twilight Event 2
23- 26/01/10	Sat/ Tues	CiC	0730	CiC Rockingham Cruise with day sail to Garden Island
23/01/10	Sat	Dinghy Division	0945	Dinghy Racing
23/01/10	Sat	Keelboat Division	1000	North Coast Series race 3 – Mullaloo Beach
27/01/10	Wed	Dinghy Division	1700	Dinghy Training and Meeting 1930hrs
28/01/10	Thu	Keelboat Division	1000	Short-handed Series Event 2
29/01/10	Fri	Offshore Division	1700	IRC State Championships – Race to HYC IBERIA
30/01/10	Sat	All Divisions	1030	IRC/Pot of Gold/Dash for Cash
31/01/10	Sun	All Divisions	0930	IRC Windward-leeward races RFBYC
03/02/10	Wed	Dinghy Division	1700	Dinghy Training
04/02/10	Thu	Keelboat Division	1000	Short-handed Series Event 3
05/02/10	Fri	All Divisions	1800	Twilight Event 3
06/02/10	Fri	Dinghy Division	0945	Dinghy Racing
07/02/10	Sun	Offshore Division	1000	Offshore Race 4 Fairway Buoy Race
10/02/10	Wed	Dinghy Division	1700	Dinghy Training
11/02/10	Thu	CiC	1930	CiC Meeting – 1830 Dinner – HYC
12/02/10	Fri	All Divisions	1800	Twilight Event 4
13/02/10	Sat	Dinghy Division	0945	Dinghy Racing
13/02/10	Sat	Offshore Division	1755	YWA/GBYC/RPYC FREQ BUSSELTON (Race week Feeder)
14/02/10	Sun	Keelboat Division	1330	Consistency Series 2 Race 3
14/02/10	Sun	Keelboat Division	1335	JAM Series 3
17/02/10	Wed	Dinghy Division	1700	Dinghy Training
17/02/10	Wed	Keelboat Division	1930	Monthly meeting
18/02/10	Thu	Keelboat Division	1000	Short-handed Series Event 4
19/02/10	Fri	All Divisions	1800	Twilight Event 5
20/02/10	Sat	Dinghy Division	0945	Dinghy Racing
20- 21/02/10	Sat/ Sun	CiC	TBC	CiC Longreach Cruise and Rottneest Bunker Tour
21/02/10	Sun	Keelboat Division	1000	Novice Lady Skippers Race
20- 26/02/10	Sat / Fri			GBSC Geographe Bay Race Week
24/02/10	Wed	Dinghy Division	1700	Dinghy Training and Meeting 1930hrs
26/02/10	Fri	All Divisions	1800	Twilight Event 6
27- 27/02/10	Sat/ Mon	Dinghy Division	1000	Sunset Coast Regatta/WAIODA Optimist States

28-02/03/10				NO RACING – LONG WEEKEND
27-01/03/10	Sat/Sun	CiC	1930	CiC Rockingham Cruise with mystery day sail
03/03/10	Wed	Dinghy Division	1700	Dinghy Training
4/03/10	Thu	Keelboat Division	1000	Short-handed Series Event 5
05/03/10	Fri	All Divisions	1800	Twilight Event 7
06/03/10	Sat	Dinghy Division	0945	Dinghy Racing
07/03/10	Sun	Keelboat Division	1000	HYC/ORSSC North Coast Series 4 Mullaloo Beach
11/03/10	Thu	CiC	1930	CiC Meeting – 1830 Dinner – HYC
12/03/10	Fri	All Divisions	1800	Twilight Event 8
13/03/10	Sat	Dinghy Division	1000	Dinghy Racing
13/03/10	Sat	Offshore Division	0925	YWA/MoFSC HALLS HEAD OCEAN RACE
14/03/10	Sun	Offshore Division	0925	YWA/FSC POINT ROBERT RETURN OCEAN RACE
14/03/10	Sun	Keelboat Division	1330	Consistency Series 2 Race 4/Man Overboard (H'cap)
14/03/10	Sun	Keelboat Division	1335	JAM Series 4 (H'cap)
17/03/10	Wed	Dinghy Division	1930	Monthly Meeting
17/03/10	Wed	Keelboat Division	1930	Monthly Meeting
17/03/10	Thu	Keelboat Division	1000	Short-handed Series Event 6
19/03/10	Fri	All Divisions	1800	Twilight Event 9
20/03/10	Sat	Dinghy Division	0945	Dinghy Racing
20/03/10	Sat	Keelboat Division	1000	Offshore Race 5 HYC-Rottnest
21/03/10	Sun	Keelboat Division	1030	Offshore Race 6 Rottnest-HYC
24/03/10	Wed	Dinghy Division	1700	Dinghy Training
26/03/10	Fri	Offshore Division	0925	YWA/RPYC CAPE NATURALISTE & RETURN RACE
26/03/10	Fri	All Divisions	1800	Twilight Event 10
27/03/10	Sat	Dinghy Division	0945	Dinghy Racing/Little Island Race Closing Day
27/03/10	Sat	Keelboat Division	1000	North Coast series Race 5 Mullaloo Beach
28/03/10	Sun	Dinghy Division	0900	WAYF Youth Cup
31/03/10	Wed	Dinghy Division	1700	Dinghy Training
01/04/10	Thu	Keelboat Division	1000	Short-handed Series Event 7
2-/04/10	Fri/Mon	CiC	1330	CiC Mandurah Cruise and Dawsville Cut Sail
2-4/04/10	Fri/Sun			EASTER WEEKEND
06/04/10	Wed	Dinghy Division	1700	Dinghy Training and Meeting 1900hrs
08/04/10	Thu	CiC	1930	CiC Meeting – 1830 Dinner – Pot Black
10/04/10	Sat	Offshore Division	0925	YWA/CYC/HYC MARINER CUP

11/04/10	Sun	Offshore Division	0925	YWA/CYC/HYC SHEPHERDESS CUP
11/04/10	Sun	Keelboat Division	1330	Consistency Series 2 Race 5
11/04/10	Sun	Keelboat Division	1335	JAM Series 5
14/04/10	Wed	Keelboat Division	1930	Monthly Meeting
15/04/10	Thu	Keelboat Division	1000	Short-handed Series Event 8
18/04/10	Sun	Keelboat Division	1000	Offshore Race 7 – Mindarie & Return
25/04/10	Sun	Keelboat Division	1000	ANZAC Day Diggers Cup – no points
26/04/10	Mon			ANZAC DAY HOLIDAY
30/04/10	Fri	Offshore Division	1855	YWA/FSC THE WESTENDER
01/05/10	Sat			Season close at Westender Presentation
02/05/10	Sun	Keelboat Division		Spare for re-sail
8-9/05/10	Sat/ Sun	Keelboat Division	1000	Rottnest Shovel Run
13/05/10	Thu	CiC	1930	CiC Meeting – 1830 Dinner – HYC
16/05/10	Sun	CiC	1030	Mindarie Lunch
19/05/10	Wed	Keelboat Division	1930	AGM/Monthly Meeting
22/05/10	Sat	Keelboat Division	1900	Presentation Night
23/05/10	Sun	Dinghy Division	1800	Presentation Night
29/05/10	Sat	CiC	1830	CiC End of Season Dinner and New Cruise Captains
1/06/10	Mon			FOUNDATION DAY
10/06/10	Thu	CiC	1930	NO MEETING
06/06/10	Sun	Keelboat Division	1000	Winter Series Race 1 Handicap
16/06/10	Wed	Keelboat Division	1930	Monthly Meeting
20/06/10	Sun	Keelboat Division	1000	Winter Series Race 2 Handicap
26/06/10	Sat	Offshore Division	0925	ENSIGN RACE
04/07/10	Sun	Keelboat Division	1000	Winter Series Race 3 Handicap
07/07/10	Wed	Dinghy Division	1930	Monthly Meeting
10/07/10	Sat	Offshore Division	0925	YWA/FSC MAYFLOWER RACE
14/07/10	Wed	Keelboat Division	1930	Monthly Meeting
18/07/10	Sun	Keelboat Division	1000	Winter Series Race 4 Handicap
24/07/10	Sat	Offshore Division	0925	YWA/FSC COLARDORA RACE
01/08/10	Sun	Keelboat Division	1000	Winter Series Race 5 Handicap
15/08/10	Sun	Keelboat Division	1000	Winter Series Race 6 Handicap
15/08/10	Sun	Keelboat Division	1300	Winter Series BBQ windup & presentations

1.0 Sailing Section Committee Contacts

Rear Commodore	Chris Grant	9243 7951 0438 363 127
Cruising Captain	Steve & Miriam Wholer	9448 7854 0407 487 855
Dinghy Captain	Brad Utting	9307 1756 0415 701 919
Keel Racing Captain	Terry Mather	9447 97846 0408 016 469

HILLARYS YACHT CLUB - CRUISING IN COMPANY OBJECTIVES:

- **To promote safer boating**
- **To increase our knowledge of local waters**
- **To share knowledge and experiences**
- **To encourage camaraderie among people of similar interests**

2.0 Cruising in Company Information

Who are we? The group was formed in 1994 and membership has grown steadily. New members are always welcome.

What do we do?

Weekend cruises are organised approximately twice a month from around the end of September to early May. We sail to destinations at Rottnest Island and along the coast between Mandurah in the south and Two Rocks in the north. There is an extended cruise to Busselton in late Feb for the Geographe Race week. Activities such as meals at restaurants, barbeques and visits to local places of interest are organised on these cruises.

We meet at the club on the second Thursday evening of each month. We have dinner together, an address by a guest speaker and briefings for the forthcoming cruises. Why not join us one evening and get to meet the fellow cruisers?

What do you need to join us?

Membership of the Hillarys Yacht Club, and a sense of fun and adventure!!
Contact Cruise Captains for information & details.

Hillarys Yacht Club
Home of the Hillarys Sailing Team
Dinghy Section Committee

Dinghy Captain	Brad Utting	0415 701 919
Secretary	Jenn Suffield	0401 959 300
Treasurer	Simon Davenport	0438 595 496
Race Officer (Club)	Chris Tennent	9246 5992 0401 135 127
Race Officer (Regatta) Training Manager	Chris Kelly	9246 2833
Rescue Boat Coordinator	Jim Suffield	9409 9761 0417 987 980
Results Officer	Deborah Fisk	9245 4850
Youth Representative	Jenn Suffield	0401 959 300
Laser Representative	Brad Utting	0415 701 919
Mirror Representative	Mark Pitt	9448 2241 0409 112 769
Optimist Representative	Adam Brett	0409 104 723
Canteen Managers	Lynda Bailey Brett Bailey	9306 2983 9306 2938 0417 930 548
Trophies	Brett Bailey	9306 2983 0417 930 548
On Beach Coordinators	Keith Fisk Brett Bailey Fred Tronccone	9245 4850 0437 700 110 9306 2983 0417 930 548 9246 2636 0411 406 655

Hillarys Yacht Club Dinghy Sailing Instructions

Organising Authority Hillarys Yacht Club (HYC)

4.1 Rules

- 4.1.1 The series will be governed by the Rules as defined in *The Racing Rules of Sailing (2009 – 2012)* and the prescriptions of Yachting Australia (YA) The rules of the relevant Class associations will apply, except as any of these are changed by these Sailing Instructions.
- 4.1.2 The Special Regulations of Yachting Australia, Part 2, will apply.

4.2 Eligibility

- 4.2.1 To contest any series or race the skipper and crew must be members of Hillarys Yacht Club or invited clubs, and must have paid the relevant race fee.
- 4.2.2 Skippers and crews that are not members of Hillarys Yacht club may participate in invitational races, and not more than three (3) summer or winter series race days. After this time, skippers and crews must apply to become members of Hillarys Yacht Club to continue racing, or obtain approval by the race committee.
- 4.2.2 Skippers and crews must be members of Hillarys Yacht Club to be eligible for series prizes.

4.3 Notices to Competitors

Notices to Competitors will be posted on the Official Dinghy Division Notice Board, which will be located inside or near the Dinghy Shed.

4.4 Changes to Sailing Instructions

- 4.4.1 Any changes to the Sailing Instructions or schedule of races will be posted on the Official Dinghy Division Notice Board not less than sixty (60) minutes prior to the scheduled start time of the affected race day.
- 4.4.2 Flag 'L' will be displayed from the signal mast on the HYC Start Tower to indicate a change to sailing instructions or schedule of races. This flag shall be displayed until the start time of the first race to which the changes apply.

4.5 Signals Made Ashore

- 4.5.1 Signals made ashore will be displayed on the signal mast at the Hillarys Yacht Club Start Tower adjacent to the Dinghy shed.
- 4.5.2 When the AP (answering pennant) flag is displayed ashore, "1 minute" is replaced with "not less than 30 minutes" in the race signal AP.

4.6 Schedule of Events

- 4.6.1 Schedule of race days, training events and club regattas are located under Hillarys Yacht Club Dinghy Sailing Programme Season 2009/2010.
- 4.6.2 Changes to start times in the 2009/2010 Sailing Handbook will be displayed on the official Dinghy Division Notice Board.
- 4.6.3 Handicaps will be displayed on the official Dinghy Division Notice Board.

4.7 Class Flags

4.7.1 The class flag(s) will be:

- | | |
|--------------------|---------------------------------------|
| (a) Laser Full Rig | White Flag with Red Laser Insignia |
| (b) Laser Radial | Green Flag with White Laser Insignia |
| (c) Laser 4.7 | Yellow Flag with White Laser Insignia |
| (d) Mirror | Red Flag with Black Mirror Insignia |
| (e) Optimist | White Flag with Black Insignia |

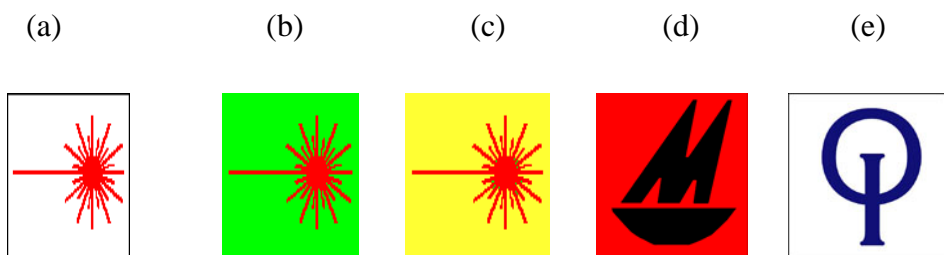

4.7.2 Fleets may be combined for starts, and may all start under the same class flag, as designated by the Race Officer during the briefing

4.8 The Course

- 4.8.1 The diagrams in Attachment A show the courses, including the approximate angles between legs, the order in which marks are to be passed, and the side on which each mark is to be left.
- 4.8.2 No later than the preparatory signal, the Race Committee Boat OR Start Tower shall display a numeral pennant indicating the course to be sailed.
- 4.8.3 The Laser Radial course will be posted on the notice board 1 hour before the briefing.
- 4.8.4 All mark rounding are to port, unless otherwise stated in the course with an “S” immediately following the mark.

4.9 Marks

- 4.9.1 Marks will be large inflatable yellow buoys. The Optimist class will use orange pimple buoys for marks 1A and 2A.

- 4.9.2 Any replacement marks will be orange buoys.
- 4.9.3 The starting and finishing marks will be orange buoys with a pole and red flag on top at one end, and a race committee start boat or start tower at the other end.

4.10 The Start

- 4.10.1 Races will be started in accordance with rule 26.
- 4.10.2 *Boat Start*: The starting line will be between a mast or staff displaying an orange flag on the Start Boat at the starboard end and the port end starting mark.
- 4.10.3 Any buoy may be permanently streamed from the Race Committee Boat from the time of the warning signal until all boats have started. The buoy is deemed part of the Committee Boat and any boat touching the buoy or passing between it and the Race Committee Boat shall be deemed to have touched the Committee Boat.
- 4.10.4 *Tower Starts*: The starting line will be between a mast or staff displaying an orange flag on the Start Tower and the starting mark.
- 4.10.5 Boats whose warning signal has not been made shall keep clear of the starting area.
- 4.10.6 A boat starting later than 10 minutes after her starting signal will be scored Did Not Start without a hearing. This changes rule A4.
- 4.10.7 Boats that have started shall not cross a start/finishing line while an orange flag is displayed on the Race Committee Boat or Race Committee Start Tower unless they are starting or finishing, or correcting an error to comply with rule 28.1.

4.11 Change of the Next Leg of the Course

- 4.11.1 To change the next leg of the course, the race committee will lay a replacement mark (or move the finishing line) and remove the original mark as soon as practicable.
- 4.11.2 The change of course will be signaled by the race committee before the leading boat has begun the leg, although the new mark may not be in position.
- 4.11.3 Any mark to be rounded after the new mark may be relocated without further signaling to maintain the course configuration.
- 4.11.4 When in a subsequent change a new mark is replaced, it will be replaced by an original mark and any subsequent changes will alternate the new mark and the original mark.

4.12 The Finish

The finishing line will be between a mast or staff displaying an orange flag on a Race Committee Boat or Race Committee Start Tower and the finishing mark at the other end.

4.13 Penalty System

Penalties shall be in accordance with rule 44.

4.14 Time Limits

4.14.1 The time limit for the first boat in each race is 1 hour 10 minutes.

4.14.2 Boats failing to finish within twenty (20) minutes after the first boat sails the course and finishes will be scored Did Not Finish without a hearing. This changes rules 35, A4 and A5.

4.15 Protests and Requests for Redress

4.15.1 Protests shall be written on forms available at the Race Office located in the start tower. Protests and requests for redress or reopening shall be delivered there within the appropriate time limit.

4.15.2 For each class, the protest time limit is 60 minutes after the last boat has finished the last race of the day

4.15.3 Notices will be posted no later than 30 minutes after the protest time limit to inform competitors of hearings in which they are parties or named as witnesses. Hearings will be held in the start tower.

4.15.4 Notices of protests by the race committee or jury will be posted to inform boats under rule 61.1(b).

4.15.5 Breaches of instructions 17.1, 17.2 and 17.3 will not be grounds for protest by a boat, this changes rule 60.1(a). Penalties for these breaches may be less than disqualification if the protest committee so decides.

4.15.6 Decisions of the protest committee will be final as provided in rule 70.4.

4.16 Mediation

4.16.1 A mediation hearing will be conducted for all protests lodged in accordance with rule 61 which allege an infringement of a rule of Part 2 or 4. Such hearings will be held subsequent to the protest being lodged and prior to the protest hearing.

4.16.2 The time and place of the mediation hearing will be decided by the mediator and such advice may be given verbally. One representative of each boat shall attend the mediation hearing and no witnesses shall be allowed. The mediator shall decide the manner in which testimony is given.

4.16.3 After taking testimony at a mediation hearing the mediator shall make one of the following conclusions:

(a) The protest does not comply with rule 61 and the protestor may withdraw the protest.

(b) The matter shall proceed to a protest hearing.
(This may be because rules other than Part 2 or 4 are or may be involved, or because evidence is too complex or divergent to reach a reasonable and timely conclusion, or due to the apparent severity of the alleged infringement, or for any other reason decided by the mediator.)

- (c) No rule was broken and the protestor may withdraw the protest.
- (d) A rule was broken by one or more of the boats involved, the infringing boat(s) may accept scoring points equal to a finishing place mid-way between the boat's actual finishing place and a disqualification, and if so accepted the protestor shall withdraw the protest. (Half points shall be disregarded and the points of other boats shall not be adjusted.)

4.16.4A mediation hearing shall not be re-opened. No conclusion of a mediator shall be subject to appeal or be grounds for redress.

4.16.5 Should the protest proceed to a protest hearing then the mediator may be a member of the protest committee. Any evidence given by a mediator during a protest hearing shall be given only in the presence of the parties to the hearing.

4.17 Scoring

4.17.1 The low point scoring system of RRS Appendix A will apply.

4.17.2 A minimum of twelve (12) Club Championship races will be scheduled in any season. A number of heats may be sailed on any race day to constitute a series race and in the event of equal places for the day; results will be decided on a count back of the highest placings. In the event that boats cannot be separated by a count back they will be awarded equal scores for the day.

4.17.3 When fewer than 8 race days are completed, a boat's series score will be the total of all her race day scores.

4.17.4 When 8 to 10 race days are completed, a boat's series score will be the total of her race day scores excluding her worst.

4.17.5 When 11 or more race days are completed, a boat's series score will be the total of her race day scores excluding her two worst scores.

4.17.4 A Handicap results system may occur at the discretion of the race committee.

4.17.5 An A and B fleet results split may occur if fleet sizes permit and it is deemed appropriate by the race organisers.

4.18 Safety Regulations

4.18.1 All boats intending to race shall sign the Sign On sheets located next to the Snack Shack, adjacent to the dinghy shed, and opposite the boat ramp, or as otherwise indicated by the race officer prior to starting every race day.

4.18.2 All boats shall sign the Sign Off sheets located next to the Snack Shack, adjacent to the dinghy shed, and opposite the boat ramp, or as otherwise indicated by the race officer within twenty

(20) minutes of the last boat's finish time in the last race for every session.

4.18.3 Breaches of instructions 18.1 and 18.2 may result in a protest by the race committee.

4.18.4 Competitors shall wear personal flotation devices that comply with Yachting Australia Special Regulations Part 2 (off the beach boats) or equivalent international standard. Failure to comply with instruction 18.4 will result in protest from the race committee, and a penalty decided at the discretion of the protest committee, with instructions issued to return to shore immediately.

4.19 Official Boats

4.19.1 Support boats will be appointed by the race committee and will be identified by a flag with green over white diagonal halves.

4.19.2 Actions by official boats will not be subject to protest or request for redress.

4.19.3 Competing boats shall give right of way to support boats at all times.

4.19.4 Coaching will be permitted during club race days.

4.20 Radio Communication

A boat whilst racing shall neither make radio transmissions nor receive radio communications not available to all boats. The use of mobile telephones is not permitted.

4.21 Disclaimer of Liability

4.21.1 The responsibility for a boat's decision to participate in a race or to continue racing is his/hers alone. Competitors shall accept that their participation in the regatta is at their exclusive risk in every aspect.

4.21.2 The Organising Authority and Hillarys Yacht Club, their officers, members, servants and agents accept no responsibility in respect of loss of life, personal injury or loss or damage to property which may be sustained by reason of their participation or intended participation in sailing organised by Hillarys Yacht Club, or howsoever arising in connection with Hillarys Yacht Club.

4.22 Insurance

4.22.1 Each participating boat shall be insured with valid third party liability insurance with minimum cover of AUD \$5 000 000 (5 million) per incident.

4.22.2 By completing and signing the Entry Form, all owners and/or competitors are deemed to have made a declaration that they hold such cover.

4.23 Prizes

Prizes will be awarded as follows.

4.23.1 Club Championship

Perpetual

Honour Board (Winners only)

Skipper and Crew

Individual

Trophies for first, second and third.

Skipper and Crew.

4.23.2 Little Island Race

Perpetual

Trophy (winners only)

Skipper and Crew

Individual

Trophies for first, second and third

Skipper and Crew

4.23.3 *Club Member Awards*

Perpetual and Individual

Best Club Person

Encouragement

Most Improved Junior

Most Active Junior

4.23.4 *Consistency*

If a handicap system is in place then prizes will be awarded for the Consistency series based on the handicap results.

4.24 Rules for the determination of 23

24.1 *Best Club Person*

The Best Club Person Award is presented to the person, who in the opinion of the Dinghy captain (or someone appointed by the Dinghy Captain) does the most work and promotes Dinghy sailing beyond the normal duties of his or her position.

4.24.2 *Encouragement Award*

Awarded to the junior sailor who is trying the hardest to improve his/her sailing. (Determined by the Dinghy Captain or someone selected by the Dinghy Captain)

4.24.3 *Most improved junior*

Awarded to the junior sailor who has shown marked improvement in sailing ability since the start of the season as shown by

- Over the line results
- Improvement in racing rules knowledge
- Attitude and performance during training
- Any races outside the club

Determined by the Dinghy Captain or someone selected by the Dinghy Captain

4.24.4 *Most Active Junior*

The Most Active Junior Award is presented to the junior who contributes the most towards assisting in the running of the Dinghy Section and training courses. The most active junior is determined by the Dinghy Captain or someone appointed by the Dinghy Captain.

Additional trophies may be awarded at the discretion of the Organising Authority.

**All those taking part in the event do so at their own risk.
The Organizing Authority, its associates and appointees
accept no responsibility for any loss, damage, injury or
inconvenience incurred, howsoever caused.**

Attention is also drawn to Fundamental Rule 4 which states
“A boat is solely responsible for deciding whether or not to
start or continue racing.”

Attachment A – Courses

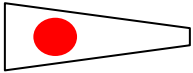

Course 1 – Numeral Pennant 1

Laser Full Rig / Laser Radial Course

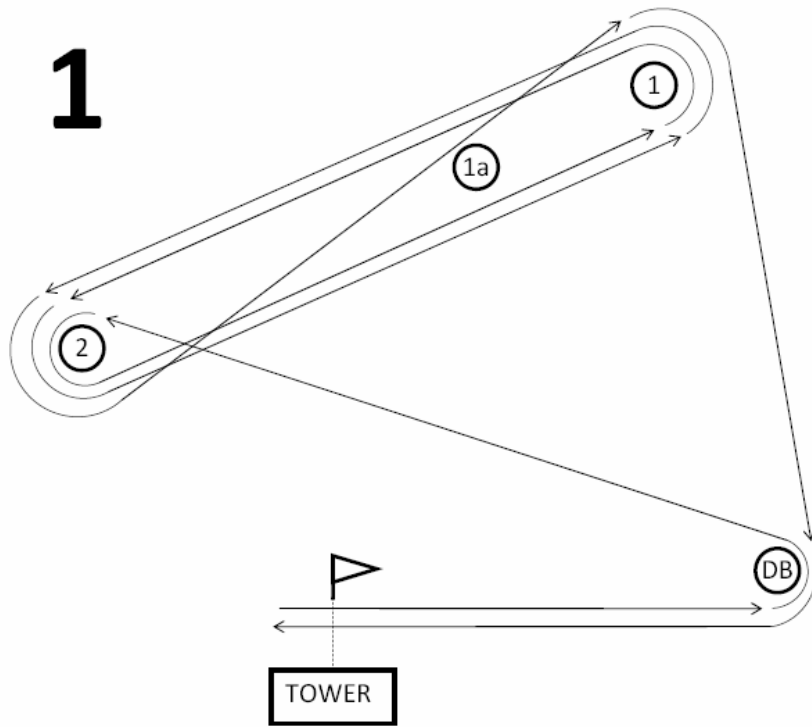

Start	DB	2	1	2	1	2	1 (s)	DB (s)	Finish
-------	----	---	---	---	---	---	-------	--------	--------

Laser 4.7 / Laser Radial / Mirror Course

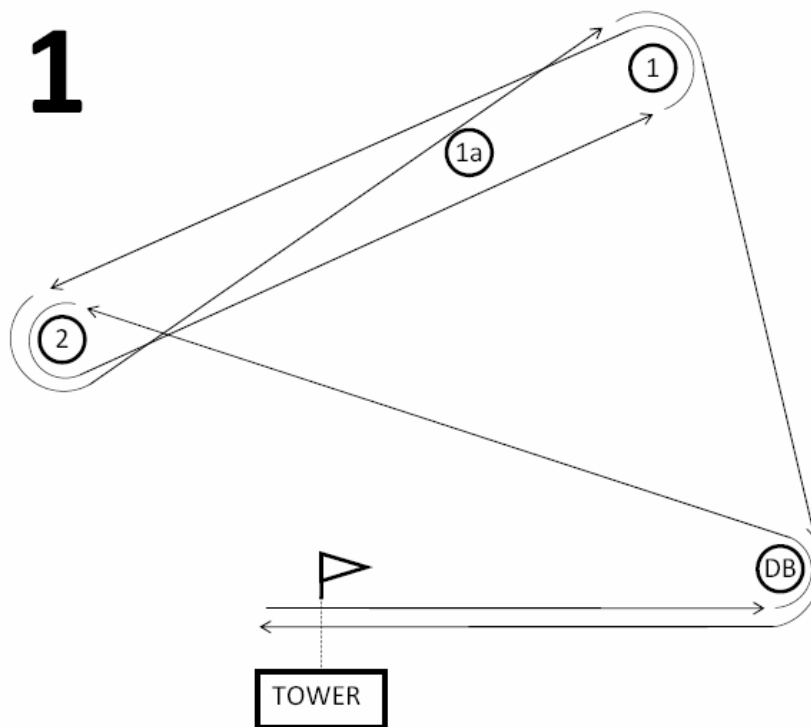

Start	DB	2	1	2	1(s)	DB(s)	Finish
-------	----	---	---	---	------	-------	--------

Optimist Course

1

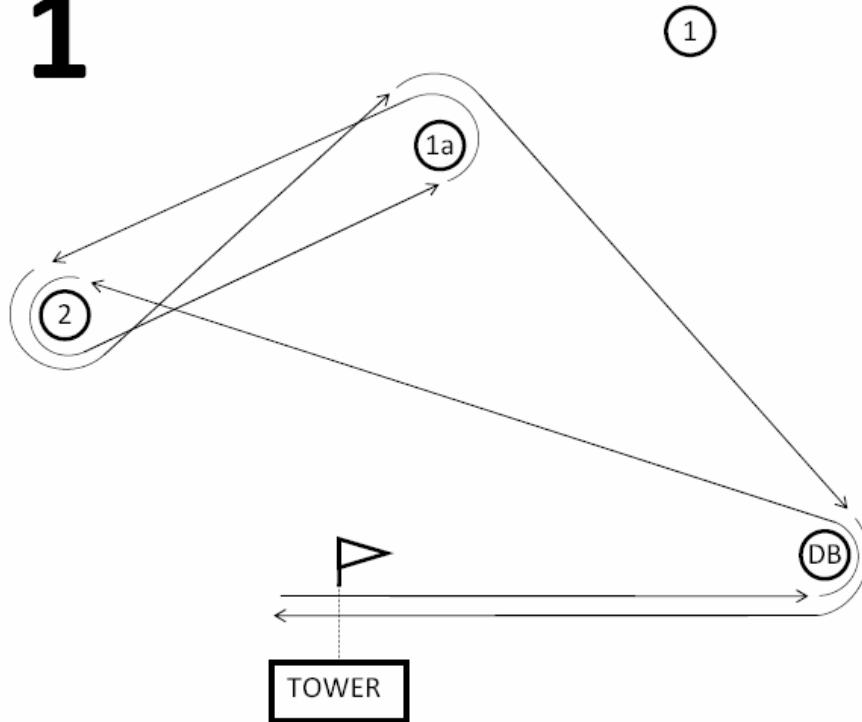

Start	DB	2	1a	2	1a(s)	DB(s)	Finish
-------	----	---	----	---	-------	-------	--------



Course 2 – Numeral Pennant 2

Laser Full Rig / Laser Radial Course

2

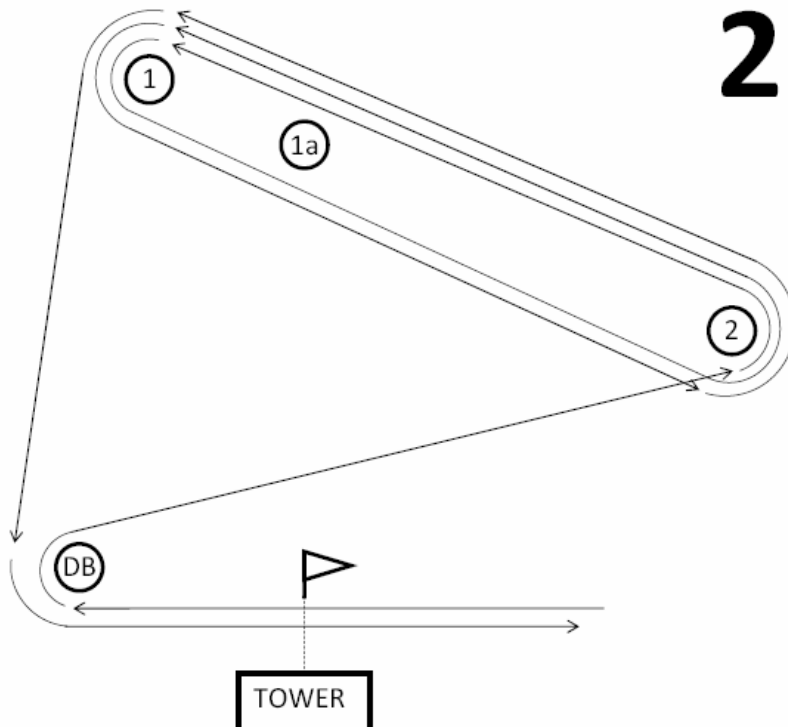

Start	DB(s)	2	1	2	1	2	1	DB	Finish
-------	-------	---	---	---	---	---	---	----	--------

Laser 4.7 / Laser Radial / Mirror Course

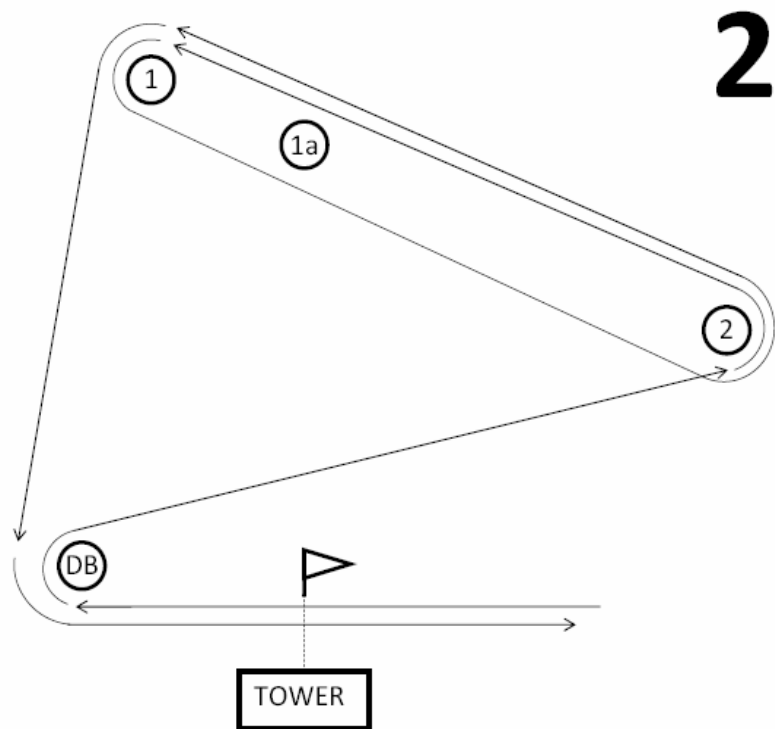

Start	DB(s)	2	1	2	1	DB	Finish
-------	-------	---	---	---	---	----	--------

Optimist Course

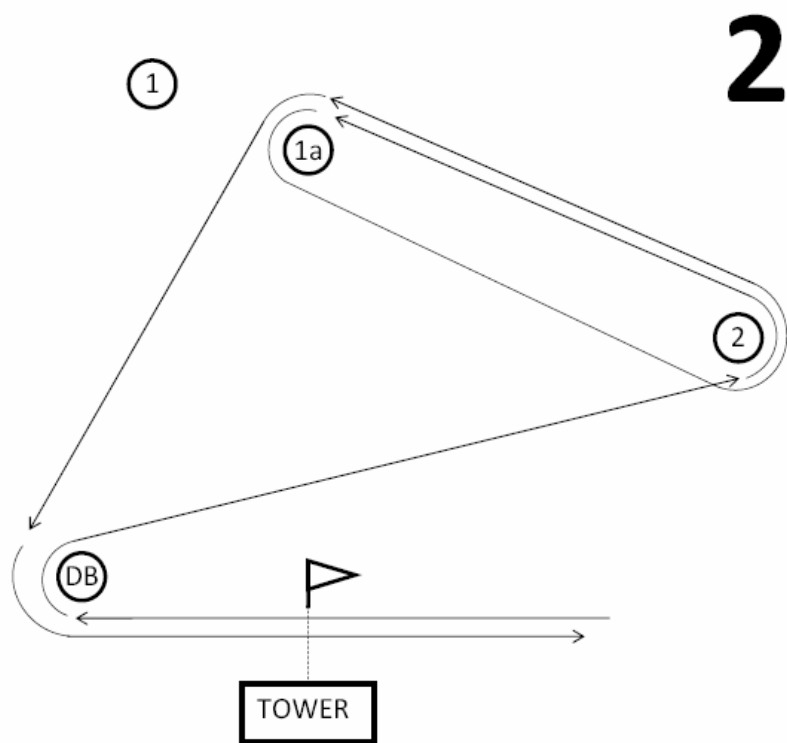

Start	DB(s)	2	1a	2	1a	DB	Finish
-------	-------	---	----	---	----	----	--------

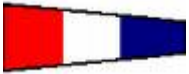

Course 3 – Numeral Pennant 3

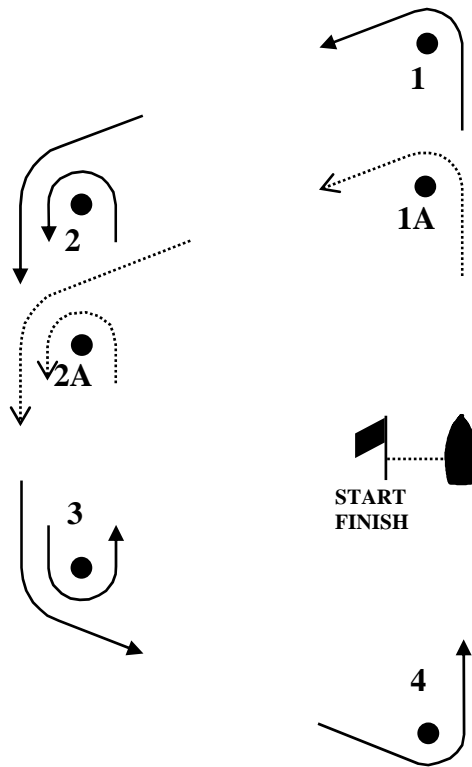

Laser Full Rig / Laser Radial

Start	1	2	3	2	3	2	3	4	Finish
-------	---	---	---	---	---	---	---	---	--------

Laser 4.7 / Laser Radial / Mirror

Start	1	2	3	2	3	4	Finish
-------	---	---	---	---	---	---	--------

Optimist

Start	1a	2a	3	2a	3	4	Finish
-------	----	----	---	----	---	---	--------

KEELBOAT RACING DIVISION

Sailing Captain	Terry Mather	9447 9846
Vice Captain	Emile Janssen	9448 8053
Handicapper	John Newman	92257594
Safety Officer	Chris Kelly	9246 2833
Secretary	Gail Riley	9448 8220
Media Officer	Des Riley	9448 8220
Trophy Officer	Clem Rogers	9306 1903
Yachting WA Rep.	Terry Mather	9447 9846
Coastal Committee/Offshore Rep	Ian Holder	9402 4768
Race Officer	Rob Gouldsmith	9402 2473

(Note : All numbers above are HOME telephone numbers)

6.0 HYC Keelboat Racing Instructions

6.1 Rules

All races will be governed by the Racing Rules of Sailing 2009-2012 (RRS) as prescribed by Yachting Australia except for any rules changed by these sailing instructions. Races are designated as being Yachting Australia Offshore category 6 except where indicated.

6.2 Eligibility to Compete

6.2.1 All skippers of yachts shall be financial members of the Hillarys Yacht Club except that visitors may take part in Invitation Races and may also be permitted to take part in other races with the prior permission of the Race Committee.

6.2.2 All yachts shall display their registered sail numbers (in accordance with ISAF Rule 77).

6.2.3 Before commencing participation in the season's program all skippers must advise the Club Handicapper of their intention to race and provide him with the necessary details to enable a handicap to be issued.

6.2.4 Prior to each race, skippers must nominate their entry to the starting officials; either at the pre-race briefing held at the clubhouse, or by hailing or by radio (and be acknowledged) to the Nominated Race Safety Officer's Boat.

- 6.2.5** Prior to each race, skippers must perform a radio check by radioing the starting officials and informing them of the number of people on their boat. Any boat not complying with the above regulation will be automatically disqualified by the race committee.
- 6.2.6** Races fees will be set by resolution of the Keelboat Section Committee from time to time.
- 6.2.7** All yachts shall have valid third party liability insurance with minimum cover of \$10 million.
- 6.2.8** All crew members must be holders of a current silver card. A limited dispensation is given to new crew members who may participate in a maximum of 3 races before obtaining a silver card.

6.3 Safety Requirements

- 6.3.1** All yachts must comply with the appropriate Safety Regulations as prescribed in Yachting Australia Racing Rules of Sailing 2009-2012, Department for Planning and Infrastructure Regulations and these Sailing Instructions.
- 6.3.2** For local races conducted entirely within the HYC Inshore Racing Area designated in rule 6.7 and for other designated races, yachts are required to conform to category 6 as stipulated in the Yachting Australia Racing Rules of Sailing 2009-2012. No inspections are required for category 6 yachts, but the Racing Committee reserves the right to inspect and disqualify non-complying yachts.
- 6.3.3** For the following races:
- Fremantle and Return Races,
 - Marmion Reef Race,
 - Fairway Race,
 - Rottnest and Return Races,
 - Any other races so designated by the race committee
- Yachts must conform to category 4 as stipulated in the Yachting Australia Racing Rules of Sailing 2009-2012. Annual inspections are required for category 4 yachts. The Racing Committee will not accept entries from non-complying yachts.
- 6.3.4** For the Mariners Cup and Shepherdess Cup, Pot of Gold and other races so designated by the race committee, yachts are required to have a current safety certificate as designated by the YWA Off-shore Handbook.
- 6.3.5** Yachts without the required current safety certificate will be ranked as DNS.
- 6.3.6** A Man Overboard Race (MOB) will be conducted under the following specific instructions:
- The MOB shall consist of a fender attached to a 9 litre bucket. The bucket shall be capable of holding water.
 - All boats will perform a simulated rescue of a MOB at any time after the

start and before the finish of the race on one UPWIND one DOWNWIND and one REACHING leg of the race. A total of three (3) rescues.

- In all cases the rescue must involve the boat in a tack or gybe maneuver.
- In the downwind leg the MOB event must occur while the spinnaker is set and the spinnaker must be reset on the leg after recovery of the MOB - UNLESS a boat elects that a spinnaker will not be used for the duration of the race

6.4 Sailing Instructions

6.4.1 Changes to these sailing instructions will be posted on the Hillarys Yacht Club Sailing notice board not later than 2 hours prior to the start of the race.

6.4.2 Changes to the schedule of races will be posted on the Hillarys Yacht Club Sailing notice board (in the Club barbecue area) not later than 1800 on the day before the change is to come into effect.

Late changes to these sailing instructions or to courses will be advised at a briefing 60 minutes prior to the start of the race.

Competitors are encouraged to attend the briefing for amendments.

Alternatively, changes may be communicated to each competing yacht on the water before the Warning Signal in which case Code Flag "L" will be flown at the Start by the Starter or on the gate yacht in the case of gate starts. Competitors are obliged to check for amendments by radio or oral communication.

6.5 Schedule of Races

Races are scheduled as shown in the Sailing Calendar.

6.6 Class Flags

Class Flags will be:

- Division I Naval Numeral 1
- Division II Naval Numeral 2
- JAM Division Naval Numeral 3

All boats shall display their division flags from their backstay.

6.7 Racing Area

6.7.1 Inshore and Mini Series courses are conducted within an area bordered by Centaur Mark, Horseshoe Reef and Little Island to the West, the shoreline of Mullaloo, Hillarys, Sorrento, Marmion, Waterman and North Beach to the East, Mindarie to the North, and Centaur Mark to the South.

6.7.2 Off-shore courses are set within an area bordered by Mindarie to the North, the coast to the East, Rockingham to the South and Rottnest to the West.

NB: SKIPPERS MUST EXERCISE EXTREME CAUTION WHEN SAILING IN THE VICINITY OF THESE REEFS AND BEACHES.

6.8 Commercial Shipping

All yachts shall, at all times, keep clear of commercial shipping. Yachts failing to do so may be subject to disqualification should a protest be lodged. The Race Committee shall instigate a protest if the Department for Planning and Infrastructure lodges a formal complaint with Yachting WA.

6.9 Courses

6.9.1 Courses shown at the end of these sailing instructions (Appendix A) may be indicated by display of the appropriate code flag A - Z on the westernmost flagpole outside of the clubhouse and/or on the start tower or start boat prior to the start. Other courses or changes to courses will be given as indicated in part 6.4.

6.9.2 Yachts will pass to the west of the western-most port channel marker in all courses (Appendix A), unless finishing and it is part of the finishing line.

6.9.3 Gate starts will commence at the first mark indicated in the published course (Appendix A).

6.10 Marks

6.10.1 The permanent marks used in Hillarys Yacht Club races are located approximately at the coordinates shown in APPENDIX B:

6.10.2 All marks are permanent floating buoys. (HYC - Orange spars, ORSSC – Red spars) unless otherwise stated.

6.11 Responsibility and Liability

6.11.1 All those taking part in Hillarys Yacht Club races, do so at their own risk and responsibility. Hillarys Yacht Club is not responsible for the seaworthiness of a yacht whose entry is accepted or of the sufficiency or adequacy of its equipment. Hillarys Yacht Club reserves the right to refuse an entry.

6.11.2 Attention is drawn to ISAF Fundamental Part 1 Rule 4 which states “The responsibility for a boat’s decision to participate in a race or to continue racing is hers alone.”

6.12 Radio Communications

6.12.1 All racing yachts shall be required to have operational radio communication apparatus for 27 Meg or VHF.

27 Meg 27.94 MHz

VHF Channel 72

6.12.2 Should the start tower be unmanned, before each race one boat will be nominated to manage radio communications between yachts operating on VHF or 27 MHz. The skipper of the nominated boat will be a race official

for the duration of the race who is responsible for:

- Logging the call-up from all boats prior to race including the number of crew on each boat
- Ensuring all boats return to safe anchorage.

6.12.3 Yachts are required to maintain a listening watch during the race as any racing instructions issued after the start will all be via radio communications. This is particularly necessary for the shortening of courses.

6.12.4 Handicap starts may also be coordinated using the radio.

6.13 Starting Line

6.13.1 Ocean Starts: The Starting Line will be an imaginary line between the signal mast on the Committee Boat and the adjacent mark. A clearance mark may be trailed from the boat when starting. This must be treated as part of the boat and its equipment.

6.13.2 Gate Starts: The Starting Line will be an imaginary line between a designated Start Mark and the stern of a designated Pathfinder yacht. The pathfinder yacht's Sail Number shall be provided to all skippers at the briefing.

6.13.3 Wall Starts: The starting line will be between the orange on-station flag on the start tower (or wall when there is no race officer to start the race) and a buoy placed approximately 100 metres north of the flag/start tower.

6.14 Starting Procedures

NB: Sound Signals may accompany the visual signals.

6.14.1 Flying Starts

6.14.1.1.1 Committee Boat

Races will be started in accordance with RRS 26 with the warning signal given 5 minutes before the starting signal - this may be preceded by a 1 minute signal of on station. Yachts need to stay well clear of the start line prior to warning signal to allow other divisions including dinghy classes to start.

6.14.1.1.2 Tower Starts

Races may be started in accordance with RRS 26 with the warning signal given 5 minutes before the starting signal. Sound signals may also be given by the Start Committee which may include a designated yacht.

Alternatively a 10 minute countdown shown on the timing light tower may be used.

6.14.2 Handicap Starts

6.14.2.1 Handicap starts will involve a tower start using the club timing lights.

6.14.2.2 The Sailing Instructions will include start times for all yachts and

the designated Start Mark.

6.14.2.3 Boats start at the fall of their starting number.

6.14.2.4 A boat shall not start prior to the fall of its allocated start number. A boat starting early will be penalized by adding to her elapsed time, 2 minutes plus 1 minute for each part or full minute by which her actual starting time preceded her designated start time.

6.14.2.5 No individual recall will be signaled and no boat shall restart.

6.14.3 Gate Starts - Designated by International Code Flag "J".

Commencement of Starting period

The *pathfinder* yacht will sail close-hauled on a port tack, passing just to leeward of the starting mark. The *pathfinder* yacht will display an orange flag when making the final approach for the gate start. Once the *pathfinder* has passed the Start Mark all other yachts must cross the imaginary line between the stern of the *pathfinder* and the Start Mark on starboard tack to qualify as starters.

The *pathfinder* will continue to sail close-hauled on port tack for two minutes.

The *pathfinder* yacht shall not be impeded by other yachts during the starting period.

Completion of Starting Period

Two minutes after the commencement of the Starting Period, the *pathfinder* yacht will go about onto starboard tack and then has no more immunity from other starters.

Late starters shall qualify by crossing the approximate Start Line on starboard tack within their own length of the Start Mark.

6.14.4 Timed Starts

In the absence of officials in the start tower or in isolated start locations (eg Rottneest or Fremantle) a time, based on GPS, may be nominated as the race start time.

In such timed starts a yacht(s) will be deemed to have broken the start line when at least two competing yachts of any division taking part in the start (i) raise protest flags and (ii) advice the offending yacht(s) accordingly by hailing or radio call.

6.15 Finishing Line

6.15.1 The finishing line will be the Start Line. Its position however, may be changed from the Start Line position. It is to be crossed from the direction of the last mark.

6.15.2 From the time the orange "On Station" flag is flown from the yardarm of

the start tower or the Committee Boat, yachts must not pass through the finishing line unless finishing.

6.15.3The Finish Line for races with an indicated "Lighthouse" finish will be an imaginary line between the green marker on the Northern end of the Southern breakwater and the outermost (i.e. Westernmost) Port Channel Mark. (Note that the Channel marker, green marker and the lighthouse lie in a straight line).

6.16 Shorten Course

Courses may be shortened for a number of reasons. The signal to shorten the course will be given by one of the methods indicated below.

6.16.1A shortened course may be indicated by International Code Flag "S" flown from the masthead of the Committee boat. The signal may be accompanied by two sound signals. Finish the race at the prescribed Finishing Line at the end of the leg still to be completed by the leading yacht.

6.16.2At a rounding mark: Finish between that mark and Committee Boat and in the direction from the previous rounding mark. The Finish Boat will be flying the orange "On Station" flag and the International Code Flag "S". The Committee Boat may be stationed on either side of the mark.

6.16.3The shortening of courses may also be advised via radio 27.94 MHZ and VHF Channel 72, if no Committee Boat is in use. It is the responsibility of each yacht to keep a listening watch on either 27.94 MHZ or VHF channel 72.

6.17 Time Limits and Finishing Times

6.17.1The time limit will be 3.5 hours or other time nominated by the Race Committee. Yachts failing to finish within 60 minutes after the first yacht in their own division finishes will be scored as Did Not Finish (DNF).

6.17.2The time limit will be 6:00pm for all offshore races and all yachts failing to finish by 6:00pm will be scored as Did Not Finish.

6.17.3Skippers need to be prepared to record their own finishing times as personnel may not be available to record these times.

6.18 Missing Marks

If a mark is missing or has shifted to a location nowhere near its correct position then yachts shall round the approximate position using a GPS or dead reckoning.

6.19 Results

The results for individual races will be awarded within 60 minutes of the last boat finishing unless there is a protest.

The results of the offshore return races (Fremantle, Fairway, Mindarie and Rottneest) will be presented within 60 minutes of the last boat completing the return race. Deadlocks will be broken by awarding the best position to the boat that has the lowest combined corrected Time.

6.20 Protests

6.20.1 Protests shall be written on forms available at the race office and delivered there within 60 minutes after the time of the last yacht to finish.

6.20.2 Protests will be heard in approximately the order of receipt as soon as possible.

6.20.3 Protest notices will be posted within 30 minutes of the protest time limit to inform competitors where and when there is a hearing in which they are parties to a hearing or named as witnesses.

6.20.4 If the places in a race might be affected by a protest, pennants will be presented at the next presentation.

6.21 Mediation

6.21.1 A Mediation hearing will be conducted for all protests lodged in accordance with rule 61 which allege an infringement of a rule of Part 2 or 4. Such hearings will be held subsequent to the protest being lodged and prior to the protest hearing.

6.21.2 The time and place of the mediation hearing will be decided by the mediator and such advice may be given verbally. One representative of each boat shall attend the mediation hearing and no witnesses shall be allowed. The mediator shall decide the manner in which testimony is given.

6.21.3 After taking testimony at mediation hearing the mediator shall make one of the following conclusions:

(i) The protest does not comply with rule 61 and the protestor may withdraw the protest.

(ii) The matter shall proceed to a protest hearing.
(This may be because rules other than Part 2 or 4 are or may be involved, or because evidence is too complex or divergent to reach a reasonable and timely conclusion, or due to the apparent severity of the alleged infringement, or for any other reason decided by the mediator.)

(iii) No rule was broken and the protestor may withdraw the protest.

(iv) A rule was broken by one or more of the boats involved, the infringing boat(s) may accept scoring points equal to a finishing place mid – way between the boat’s actual finishing place and a disqualification, and if so accepted the protestor shall withdraw the protest. (Half points shall be disregarded and the points of other boats shall not be adjusted.)

6.21.4 A mediation hearing shall not be re- opened. No conclusion of a mediator

shall be subject to appeal or be grounds for redress.

6.21.5 Should the protest proceed to a protest hearing then the mediator may be a member of the Protest Committee. Any evidence given by a mediator during a protest hearing shall be given only in the presence of the parties to the hearing.

6.22 Distinguishing Flags - Support Boats

Support Boats will fly a green and white diagonal halved pennant and shall have a right of way over all competing yachts.

6.23 Handicaps

6.23.1 Corrected times for the award of point scores will be calculated according to the handicap procedure in Appendix D.

6.23.2 New yachts, yachts with significant changes to hull, keel, sails etc, or changes to skipper/crew which have the potential for significantly affecting the performance of the yacht will be dealt with as designated in Appendix D.

6.23.3 Handicaps are monitored by the Handicap Officer and are subject to amendment as per Appendix D.

6.24 Consistency Points

Each yacht shall drop its worst result in the relevant series where 5 or more races are completed. All other results count towards consistency awards as detailed in appendix D.

A bonus points scoring system is used and within each division consistency points will be awarded on the basis of race results positions as shown below.

1 st	0 Points
2 nd	3 Points
3 rd	5.7 Points
4 th	8 Points
5 th	10 Points
6 th	11.7 Points
7 th and above	Position + 6 Points
DNS, DNF, DSQ	7 Point plus the number of competitors
DNC	8 Points plus the number of competitors

In the event of a tie at the end of the season the trophy will be awarded to the yacht with the most first places, and when the tie remains, then the most second places, and so on.

6.25 Advertising

Hillarys Yacht Club races are classified as Category C in accordance with Appendix 1 of the Racing Rules of Sailing 2009 – 2012.

6.26 Twilight Sailing

Twilight Sailing will be conducted as scheduled in the program subject to weather conditions. The emphasis is on informal participation.

As a general guideline twilight events **will not be sailed when winds are forecast to be in excess of 20 knots** at the scheduled start time of the twilight event.

There will be a briefing 30 minutes before the scheduled start time. Events will commence and finish at the normal Start line.

Appendix A1 - Sailing Courses – Inshore

Unless otherwise nominated, races start at the designated time at the start line off the north wall of the marina and the finish line will be the starting line crossing in an easterly direction.

The North Coast Series start – finish line will be a boat off Mullaloo Beach.

Note: the distances given are those between each pair of marks

Course: --- A ---						
Wind: South West-North East 15-20 knots						
Division	I			II		
Start: Both Divisions : Wall Start or Boat start at Sorrento.						
	C	Port	3.82	W	Port	3.00
	B	Port	1.59	B	Port	0.73
	S	Port	1.56	S	Port	1.56
	C	Port	2.89	W	Port	1.95
	B	Port	1.59	B	Port	0.73
	S-sh	Port	1.56	S-sh	Port	1.56
	A	Stb.	1.03	A	Stb.	1.03
Finish:	Start Line		2.10	Start Line		2.10
	Total Distance		16.14			12.66
Course: --- B ---						
Wind: South West – North West >20 knots						
Division	I			II		
Start: Both Divisions : Wall Start or Boat start at Sorrento.						
	W	Stb.	2.80	W	Stb.	2.80
	F	Stb.	1.47	F	Stb.	1.47
	S	Stb.	1.03	S	Stb.	1.03
	A	Stb.	1.03	W	Stb.	1.95
	S	Stb.	1.03	F-sh	Stb.	1.47
	W	Stb.	1.95	S	Stb.	1.03
	F-sh	Stb.	1.47	A	Stb.	1.03
	S	Stb.	1.03			
	A	Stb.	1.03			
Finish:	Start Line		2.10	Start Line		2.10
	Total Distance		14.94			12.88

Course: --- C ---						
Wind: South West – North East Winds>20knots						
Div:	I			II		
Start:	Wall Start			Wall Start		
	HYC L	Stb.	0.90	HYC L	Stb.	0.90
	Cow Rocks	Port	0.90	Cow Rocks	Port	0.90
	ORSSC M	Port	2.10	ORSSC M	Port	2.10
	HYC H	Stb.	2.10	HYC H	Stb.	2.10
	HYC F	Port	1.60	HYC F-sh	Port	1.60
	HYC S	Stb.	1.03	HYC S	Stb.	1.03
	HYC A-sh	Stb.	1.03	HYC A	Stb.	1.03
	HYC S	Stb.	1.03	HYC M	Port	1.20
	HYC A	Stb.	1.03			
Finish:	Start Line		2.10	Start Line		1.00
Total Distance			13.82	11.86		

Course: --- D ---						
Wind: South West, North East >20 knots						
Division	I			II		
Start: Both Divisions : Wall Start or Boat start at Marina.						
	F	Port	1.60	F	Port	1.60
	M	Stb.	0.86	M	Stb.	0.86
	W	Port	2.10	W	Port	2.10
	B	Port	0.73	B	Port	0.73
	S	Port	1.56	S	Port	1.56
	W	Port	1.95	A-sh	Stb.	1.03
	S-sh	Port	1.95	S	Port	1.03
	A	Stb.	1.03	A	Stb.	1.03
Finish:	Start Line		2.10	Start Line		2.10
Total Distance			13.88	12.04		

Course: --- E ---						
Wind: North West, South East <33knots						
Div	I			II		
Start:	Wall Start			Wall Start		
	L	Port	0.90	L	Port	0.90
	M	Stb.	1.02	M	Stb.	1.02
	B	Stb.	1.86	A	Stb.	1.20
	L	Port	2.56	L	Port	1.82
	A-sh	Stb.	1.82	A-sh	Stb.	1.82
	L	Port	1.82	L	Port	1.82
	F	Port	1.08	F	Port	1.08
Finish	Start Line		1.60	Start Line		1.60
Total Distance			12.66	11.26		

Course: --- F ---						
Wind: East, West < 33 knots						
Division	I			II		
Start: Both Divisions - Wall or Boat start						
	L	Port	0.90	L	Port	0.90
	S	Stb.	1.47	S	Stb.	1.47
	F	Stb.	1.03	F	Stb.	1.03
	M	Stb.	0.86	M	Stb.	0.86
	S	Stb.	0.46	S	Stb.	0.46
	A-sh	Stb.	1.03	A-sh	Stb.	1.03
	F	Stb.	0.78	F	Stb.	0.78
	S	Stb.	1.03			
	F	Stb.	1.03			
Finish	Start Line		1.60	Start Line		1.60
Total Distance			10.19	8.13		

Course: --- G ---						
Wind: South East, North West < 15 knots						
Div	I			II		
Start: Both Divisions - Wall or Boat start						
	L	Port	0.90	L	Port	0.90
	S	Stb.	1.47	S	Stb.	1.47
	B	Stb.	1.56	A	Stb.	1.03
	F	Stb.	1.51	M	Port	1.20
	M	Port	0.86	L	Port	1.02
	L	Port	1.02	S-sh	Stb.	1.47
	S-sh	Stb.	1.47	F	Stb.	1.03
	F	Stb.	1.03			
Finish:	Start Line		1.60	Start Line		1.60
Total Distance:			10.88	9.72		

Course: --- H ---						
Wind: South West, North East 15-20 knots						
Div	I			II		
Start: Both Divisions - Wall or Boat start						
	F	Port	1.60	F	Port	1.60
	M	Stb.	0.86	M	Stb.	0.86
	W	Port	2.10	W	Port	2.10
	B	Stb.	0.73	B	Stb.	0.73
	SB-sh	Port	2.30	SB-sh	Port	2.30
	S	Port	3.50	S	Port	3.50
	A	Stb.	1.03			
Finish:	Start Line		2.10	Start Line		1.40
Total Distance:			14.22	12.49		

Appendix A2 – Keelboat Midi-Series Courses

Note : Only overall distances given as marks are all ≤ 1.5 nM between each mark

Course: --- I ---						
Wind: South West or North East						
Div	I			II		
Start	Wall			Wall		
	F M F M	Port Port Port. Port		F S	Port Port	
Finish	Start to East			Start to East		
Total Distance			5.6	3.7		

Course: --- J ---						
Wind: South East, North West						
Division	I			II		
Start	Wall			Wall		
	L M L M	Port Port Port Port		L S	Port Port	
Finish	Start to East			Start to East		
Total Distance			5.5	3.5		

Course: --- K ---						
Wind: South or North						
Div	I			II		
Start	Wall			Wall		
	F L F L	Stb. Stb. Stb. Stb.		A L	Stb. Stb.	
Finish	Start to East			Start to East		
Total Distance			5.9	3.8		

Course: --- L ---						
Wind: West or East						
Division	I			II		
Start	Wall			Wall		
	F S F S	Port Port Port Port		F S	Port Port	
Finish	Start to East			Start to East		
Total Distance			5.9	3.8		

Appendix A3 – North Coast Series

The North Coast Mini-Series will be run in conjunction with Ocean Reef Sea Sports Club over a course consisting of a start/finish line (a Committee boat as starboard end and a flag mark at port end) and two large rounding marks.

Rounding marks (Windward marks W1 and W2) will be about 1.0 mile and 0.8 mile to windward for Div I and Div II fleets respectively. One leeward mark will be about 50m to port of the start line as indicated (right). After the start, yachts will round the windward mark first, then leeward and windward marks in that order, before crossing the finish line.

Course (unless indicated otherwise in the Sailing Instructions):-

Div I Start – W1 - L – W1 - Finish

Div II Start – W2 - L – W2 - Finish

All roundings to Port

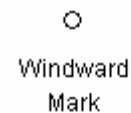

A diagram showing a single circle representing a mark. Below the circle, the text "Windward Mark" is written.

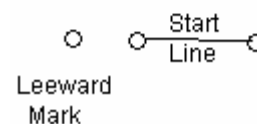

A diagram showing a horizontal line with three circles at its ends. The middle circle is labeled "Start Line". To the left of the line, there is a single circle labeled "Leeward Mark".

Each series will consist of one, two or three races (depending upon time and weather conditions) with subsequent races starting 10 minutes after the last yacht finishes in the previous race.

Handicaps are based on club handicaps and will be adjusted during this series.

A Notice of Race and Supplementary Sailing Instructions for the series will be issued before the first race.

Appendix A4 – Offshore Sailing Courses

Hillarys to Fremantle Race:				
Division	I		II	
Start	Both Divisions - Wall or Boat start.			
	GR Red A Campbell Burnell FHredA FHgreen 1	Port Stb. Stb. Port Port	GR Red A Burnell FHredA FHgreen1	Port Stb. Port Port
Finish	South Mole Finish Line.		South Mole Finish Line	
Distance		21.0nm		16.0nm
Yachts must NOT enter the Swanbourne Exclusion zone.				

The South Mole Start/Finish Line shall be between the South Mole Lighthouse and an outer buoy bearing 195 deg true distance 0.1 nautical miles from the South Mole Light

Fremantle to Hillarys Race:				
Division	I		II	
Start	Both Divisions : South Mole Start			
	FHgreen 1 Burnell B A W	Stb Port Port Port Stb	FHgreen1 Burnell B	Stb Port Port
Finish Line	Wall		Wall	
Distance		20.2nm		15.8nm
Yachts must NOT enter the Swanbourne Exclusion zone.				

Marmion Reef Race				
Division	I		II	
Start	Both Divisions - Wall or Boat start			
	L B C Marmion Reef ORSSC T ORSSC M M W B S A	Port Stb. Stb. Stb. Stb. Stb. Stb. Port Port Port Stb.	L B C Marmion Reef ORSSC T ORSSC M M A	Port Stb. Stb. Stb. Stb. Stb. Stb. Stb.
Finish	Wall		Wall	

Hillarys to Mindarie				
Division	I		II	
Start	Both Divisions - Wall or Boat start.			
	L F Cow Rocks Burns Rock	Port Port Port Port	L Cow Rocks Burns Rock	Port Port Port
Finish Line	Imaginary line running due west of northern end of southern breakwater. Pass within 200 metres of end of the wall.			

Mindarie to Hillarys				
Division	I		II	
Start	Gate Start or GPS timed start off Mindarie Breakwater			
	Burns Rock Cow Rocks	Stb. Stb.	Burns Rock Cow Rocks	Stb. Stb.
Finish Line	Normal Wall finish in Westerly direction			

Hillarys to Rottneest				
Division	I		II	
Start	Both Divisions - Wall or Boat start.			
	A S B C Fairway East Windmill	Port Stb. Stb. Stb. Port Stb.	S B C Fairway East Windmill	Stb. Stb. Stbd. Port Stb.
Finish Line	Imaginary line running north from Phillip Rock red warning beacon to South channel entrance marker beacon.			

Rottnest to Hillarys				
Division	I		II	
Start	Imaginary line running north from Phillip Rock red warning beacon to South channel entrance marker beacon.			
	Fairway	Port	Fairway	Port
	B	Port	B	Port
	S	Port	S	Port
	A	Stb.		
Finish Line	Normal finish line			

Fairway Race				
Division	I		II	
Start	Both Divisions - Wall or Boat start.			
	L	Port	L	Port
	A	Port	B	Stb.
	S	Stb	C	Stb.
	B	Stb.	Fairway	Port
	C	Stb.	GRredA	Port
	Fairway	Port	S	Port
	GRredA	Port	M	Stb
	S	Port		
	M	Stb		
Finish Line	Normal finish line			

Appendix B Race marks

HYC Marks

MARK	South	East
"A" Anchor	31° 51.13'	115° 43.85'
"B" Beach	31° 51.76'	115° 44.31'
"C" Centaur	31° 52.80'	115° 42.90'
"C" Mark is the Centaur Reef South Cardinal Mark.		
"F" Foam	31° 50.55'	115° 43.24'
"H" Hillarys	31° 49.23'	115° 44.18'
"H" mark will be a temporary floating day buoy.		
"L" Little	31° 49.53'	115° 42.84'
"M" Marina	31° 49.93'	115° 43.94'
"S" Sorrento	31° 50.20'	115° 44.38'
"W" Whale	31° 52.00'	115° 43.50'
"ORSSC S"	31° 46.76'	115° 42.71'
"ORSSC M"	31° 47.07'	115° 43.72'
"ORSSC T"	31° 45.60'	115° 41.52'
"SB" Scarb Beach	31° 53.64'	115° 44.76'

Approx. location of non-Hillarys Yacht Club marks:

MARK	South	East
Campbell Buoy	31 ° 59.2'	115 ° 44.7'
Burnell Buoy	32 ° 01.4'	115 ° 44.3'
North West Exclusion Zone Buoy	31 ° 56.6'	115 ° 43.3'
South West Exclusion Zone Buoy	31° 58.9'	115 ° 43.3'
<i>Gauge Roads Entrance Buoys</i>		
Red A Entrance Buoy (GRredA)	31 ° 59.1'	115 ° 41.6'
<i>Fremantle Harbour Entrance Buoys</i>		
Red A Entrance Buoy (FHredA)	32 ° 03.3'	115 ° 43.4'
Green No 1 Entrance Buoy (FHgreen1)	32 ° 03.5'	115 ° 42.9'
South Moll Start/Finish Line Buoy	32 ° 03.4'	115 ° 43.1'
Eastern Windmill	32 ° 01.2'	115 ° 37.7'
Fairway	31 ° 57.2'	115 ° 38.9'

Appendix C Table of Bearings and Distances between marks.

	L	M	S	F	A	B	W	C	CM
L		116 1.02	130 1.47	157 1.08	154 1.8	153 2.56	170 2.53	172/18 3.28	92 0.67
M	296 1.02		306 0.46	220 0.86	186 1.2	173 1.86	193 2.1	200 3	330 0.49
S	300 1.47	308 0.46		251 1.03	208 1.0	185 1.56	205 1.95	208 2.89	319 0.93
F	337 1.08	40 0.86	71 1.03		150 0.7	150 1.51	179 1.47	193 2.27	13 1.08
A	334 1.82	6 1.2	28 1.03	330 0.78		151 0.74	201 0.92	208 1.85	356 1.62
B	333 2.56	353 1.86	5 1.56	330 1.51	331 0.7		253 0.73	232 1.59	348 2.31
W	350 2.53	13 2.1	25 1.95	359 1.47	21 0.9	73 0.73		215 0.95	5 2.48
C	3/35 3.28	20 3	28 2.89	13 2.27	28 1.8	52 1.59	35 0.95		13 3.34

L - Little M - Marina
 S - Sorrento F - Foam
 A - Anchor B - Beach
 W - Whale C - Centaur
 CM – Channel Marker

The bearing from a Mark (left column) to another Mark (top row) is given in bold. The distance (in nautical miles) is given underneath in normal type.

Note that the values may change slightly due to drift.

An automated handicap and scoring system is used which is designed to ensure that all boats are able to win a pennant at some stage during the season. The final winner of each series and the club championship is the boat which is most consistent in finishing all races and copes best with the variety of conditions encountered.

The Handicaps are calculated to give a base handicap of 0.93 for Division 1 and a handicap of 0.66 for Division 2 which have been set for season 2009-2010. This is based on the performance of boats in the previous Season and also allows for the two Divisions to be based on the same handicap base if required.

Handicaps are adjusted after each race according to the following table

1 st Place	.010 added
2 nd Place	.005 added
3 rd Place	no change
4 th Place and all other places	.005 deducted

Once the adjustments have been made the Handicaps will be NORMALISED. This instructs the system to set the handicap of the highest handicap boat to finish in that race (after recalculation) to the highest handicap for the finishing boats and all other finishing boats are adjusted pro-rata.

Boats that do not race will not have their handicap altered.

North Coast Mini Series

The combined result for each day will count as one race.

Ocean Series

All offshore races on separate days will be treated the same as individual races with equal points and handicap adjustment even though races such as Rottnest and return have one overall result.

New Yachts

New yachts joining a division will race under a handicap determined by the Handicap Officer. This initial handicap will rank the new yacht behind yachts of a similar size and performance. This handicap will be revised based on the first three race results. This could result in the yacht being moved to a different division. Thereafter the normal handicap adjustments will apply.

Fair sailing

It is a requirement that you advise the Handicap Officer of any change to keel, hull, and weight of yacht or increase in sail area. Failure to advise any significant amendment may result in a protest and/or retrospective adjustment of your handicap and results. Every effort is made to maintain a practical and efficient handicap system.

Scoring System

The Hillarys Yacht Club racing season consists of the 5 series as listed below

Winter Series - 6 or less races held every fortnight between 4th June and 13th August
Consistency 1 - 5 or less races held between Opening Day and 31st December
Consistency 2 - 5 or less races held between 1st January and 15th May
Ocean Series - 5 or less races held between Opening Day and 15th May
North Coast Mini Series - 5 or less races held between Opening Day and 15th May

The Winter Series stands alone and does not count towards overall consistency or the club championship. Similarly The Australia Day Cup Race, Anzac Cup, the twilight races and the Lady Skippers Race do not count for overall consistency or the club championship.

The Pot of Gold, The Mariners Cup and The Shepherdess Cup are part of the YWA offshore series and do not count for overall consistency or the club championship.

All other races, regardless of duration, will count for equal points in the club championship with the exception of the North Coast Mini Series races which will produce a single result for the day.

Points are awarded as detailed in section 5.22. In any series where 5 or more races are completed each yacht shall drop its worst result.

Each series will be separate from each other and prizes awarded for each series. See the Keelboat Calendar for details of Series Races. The champion yacht in each division is the yacht with the lowest total point score from all series.

The club champion is the yacht with the highest total point score using the Cox-Sprague Scoring System see <http://www.wiannosenior.org/scud-table.htm> which allocates points based on the number of boats beaten. This is the fairest way to compare results across 2 Divisions that have different numbers of competitors in each race. The boat with the highest points is awarded Club Champion.

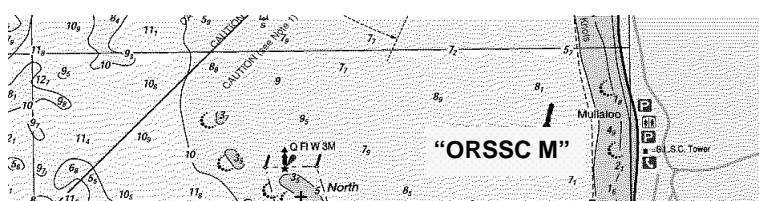

HYC Race Area

Diagram based on nautical chart
WA 957, reproduced with